

DEPEND ON
DAVEY

WATER PRODUCTS



POWERMASTER[®]

Swimming Pool Pump

Davey's premium Power Master[®] range is specifically designed to circulate swimming pool water for filtration and in-floor cleaning applications.

Reliable - Constructed of strong corrosion and U.V. resistant materials for long and reliable working life.

Built-in check valve protects pump internals from reverse flows.

Extra heavy duty, totally enclosed motor protects against the elements for long operating life.

Built-in thermal overload protects the motor against damage from over-heating.

Long Lasting - High performance Silicon Carbide mechanical seal for long life in salt & fresh water.

Performance - Powerful pumping delivers optimum flow rates for rapid pool water turnover, with quiet and efficient performance.

Convenient - Easy to remove, see through stainer lid for easy removal of leaves.

Drain plug enables simple pump drainage for easy maintenance.

Extra large strainer basket allows long intervals between cleaning & rapid priming.

Three phase model available for commercial pools and aquaculture applications.

2m power lead with 10amp Australian three pin plug fitted to all single phase models.



For your local Davey dealer visit: davey.com.au

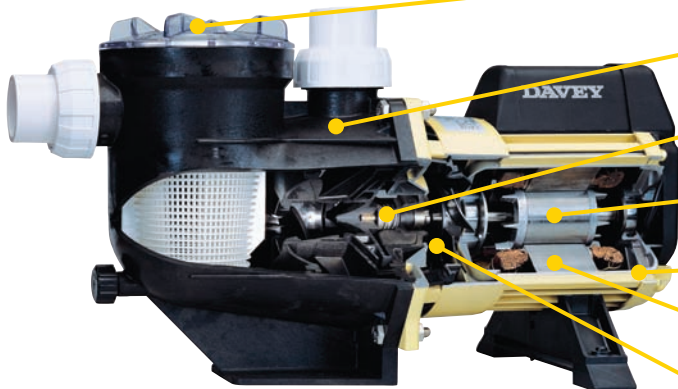

Easy to remove, see through strainer lid

Latest hydraulic design ensures the pump is highly energy efficient & whisper quiet

Silicon carbide seals for long life in salt & fresh water pools

Stainless steel shaft won't corrode or rust

Double insulated water circuit & IP56 protective enclosures for high personal safety & long motor life

Extra heavy duty high performance motor with massive power reserves for extended operating life

Huge front fan for cool running & long bearing life

ELECTRICAL DATA

	PM 200	PM 300	PM 350	PM 450	PM 4503
Voltage (V)	220-250				380-415
Phase	1				3
Supply Frequency (Hz)	50Hz				
Start Current (A)	27	27	27	40	24
Run Current (A)	5.8	6.5	7.7	10.0	3.6
Motor Input Power (W)/hp	1200	1360	1675	2300	2040
Motor Output Power (W)/hp	900	1000	1200	1775	1750
RPM	2850				
Enclosure Class (IP)	56				
Insulation Class	F				
Approval No.	V06258				

OPERATING LIMITS

Water Temperature	Max 50°C
Ambient Temperature	Max 55°C
dBa @ 1 metre	64 - (PM 200/250/300) 65 - (PM 450/3)

MODEL NUMBER IDENTIFICATION

PM	250
PM = Power Master®	250 = 250lpm @ 12m per head

HYDRAULIC PERFORMANCE

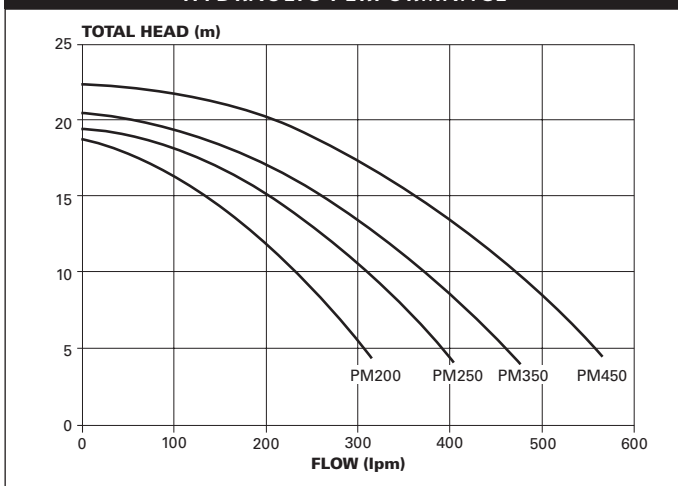

SLS DIMENSIONS

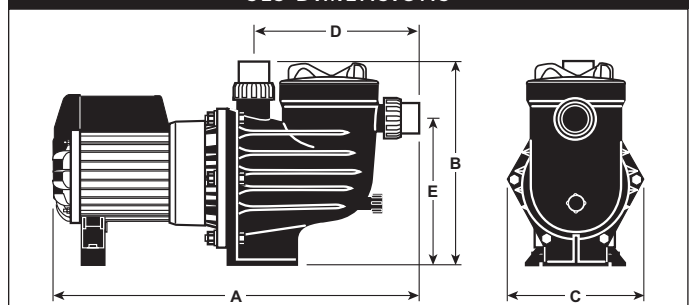

Model	A	B	C	D	E	Mounting Holes Dia.	Inlet PVC	Outlet PVC	Net Weight (kg)
PM 200	615	330	250	305	246	10	40/50*	40/50*	15.9
PM 250							40/50*	40/50*	15.9
PM 350							40/50*	50	16.0
PM 450/3							635	50	50

* Suction & delivery accept 40mm PVC pipe on the I.D. and 50mm fitting on the O.D. All dimensions in mm unless otherwise stated.

DEPEND ON
DAVEY

WATER PRODUCTS

Davey Water Products Pty Ltd
Member of the GUD Group
ABN 18 066 327 517

AUSTRALIA
Head Office and Manufacturing
6 Lakeview Drive,
Scoresby, Australia 3179
Ph: +61 3 9730 9222
Fax: +61 3 9753 4100
Website: davey.com.au

Customer Service Centre
Ph: 1300 369 100
Fax: 1300 369 119
E-mail: sales@davey.com.au

NEW ZEALAND
7 Rockridge Avenue,
Penrose, Auckland 1061
Ph: +64 9 570 9135
Fax: +64 9 527 7654
E-mail: sales@daveynz.co.nz
Website: daveynz.co.nz

Customer Service Centre
Ph: 0800 654 333

REST OF WORLD
6 Lakeview Drive,
Scoresby, Australia 3179
Ph: +61 3 9730 9121
Fax: +61 3 9753 4248
E-mail: export@davey.com.au
Website: davey.com.au

